

GENERAL CERTIFICATE OF SECONDARY EDUCATION
GATEWAY SCIENCE
ADDITIONAL SCIENCE B

Unit 2 Modules B4 C4 P4 (Higher Tier)

WEDNESDAY 11 JUNE 2008

Afternoon
 Time: 1 hour

Candidates answer on the question paper.

Additional materials (enclosed):

None

Calculators may be used.

Additional materials: Pencil
 Ruler (cm/mm)



Candidate
 Forename

Candidate
 Surname

Centre
 Number

--	--	--	--	--

Candidate
 Number

--	--	--	--

INSTRUCTIONS TO CANDIDATES

- Write your name in capital letters, your Centre Number and Candidate Number in the boxes above.
- Use blue or black ink. Pencil may be used for graphs and diagrams only.
- Read each question carefully and make sure that you know what you have to do before starting your answer.
- Answer **all** the questions.
- Do **not** write in the bar codes.
- Write your answer to each question in the space provided.

INFORMATION FOR CANDIDATES

- The number of marks for each question is given in brackets [] at the end of each question or part question.
- The total number of marks for this paper is **60**.
- A list of physics equations is printed on page two.
- The Periodic Table is printed on the back page.

FOR EXAMINER'S USE

Section	Max.	Mark
A	20	
B	20	
C	20	
TOTAL	60	

This document consists of **22** printed pages and **2** blank pages.

EQUATIONS

$$\text{speed} = \frac{\text{distance}}{\text{time taken}}$$

$$\text{acceleration} = \frac{\text{change in speed}}{\text{time taken}}$$

$$\text{force} = \text{mass} \times \text{acceleration}$$

$$\text{work done} = \text{force} \times \text{distance}$$

$$\text{power} = \frac{\text{work done}}{\text{time}}$$

$$\text{kinetic energy} = \frac{1}{2} mv^2$$

$$\text{potential energy} = mgh$$

$$\text{weight} = \text{mass} \times \text{gravitational field strength}$$

$$\text{resistance} = \frac{\text{voltage}}{\text{current}}$$

BLANK PAGE

Question 1 starts on page 4.

PLEASE DO NOT WRITE ON THIS PAGE

Answer **all** the questions.

Section A – Module B4

1 Kathy grows her own tomato plants.

(a) The soil Kathy uses does not have enough nitrate.
Some of her plants show signs of nitrate deficiency.

Describe **two** signs of nitrate deficiency the plants would show.

1

2[2]

(b) Kathy decides to use fertiliser on her soil.

Look at the picture of the bag of fertiliser.

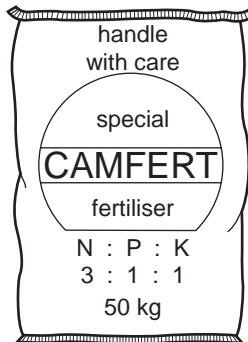

(i) The plants grown by Kathy use the nitrates.

What do the plants make using the nitrates?

.....[1]

(ii) The fertiliser also contains magnesium.

What do plants use the magnesium for?

.....[1]

(c) Kathy has grown too many tomatoes to eat all at once.
She decides to turn them into tomato chutney by cooking them with vinegar.

Vinegar helps to preserve the tomatoes.

Explain how.

.....

.....[2]

(d) Kathy's friend John also grows tomatoes.

However, John does not use any soil.

The diagram shows John's plants.

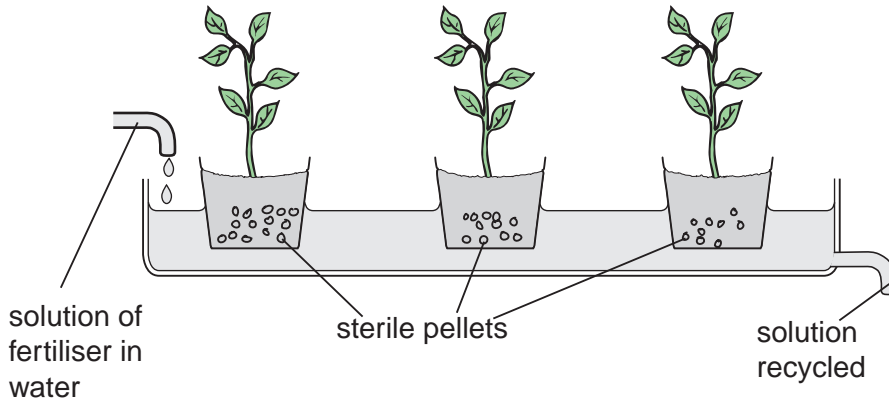

(i) Write down the name given to the method John uses.

.....[1]

(ii) Write down **one** advantage and **one** disadvantage of this method compared to growing plants in soil.

advantage.....

.....

disadvantage.....

.....[2]

[Total: 9]

2 Look at the diagram. It shows a food chain.

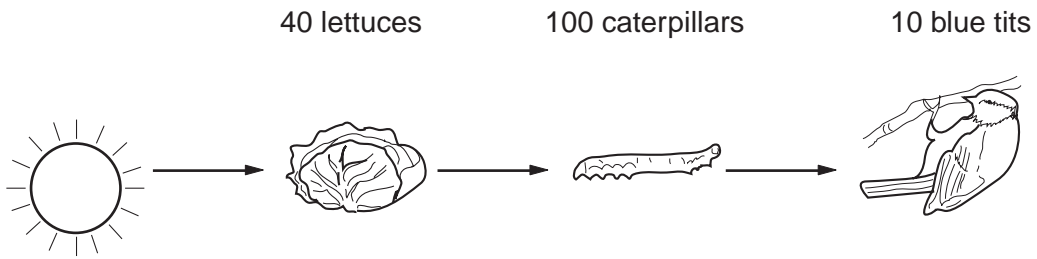

(a) (i) Finish the pyramid of **numbers** to include the caterpillars and blue tits.

Make sure the bars are drawn to scale.

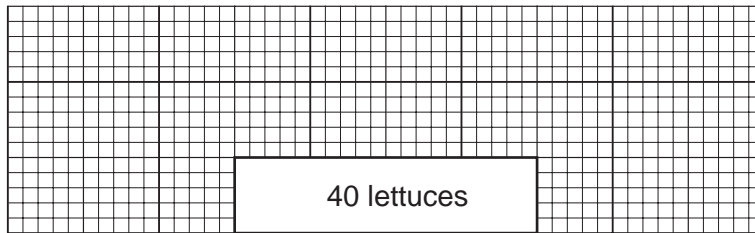

[1]

(ii) A pyramid of **biomass** for this food chain would be a different shape.

Describe how the shape would be different.
You may use a diagram to help you answer.

.....
.....[1]

(b) Energy is 'lost' from each stage of the food chain.

Write down **one** way in which energy is lost.

.....[1]

(c) When blue tits die, nitrogen in their bodies can be used by plants.

This is part of the nitrogen cycle.

The table contains some bacteria found in the nitrogen cycle.

Describe the role of each bacterium next to the name.

bacteria	role in nitrogen cycle
denitrifying bacteria	
nitrifying bacteria	
nitrogen-fixing bacteria	

[3]

[Total: 6]

8
BLANK PAGE

PLEASE DO NOT WRITE ON THIS PAGE

3 Look at the diagram.

It shows the cellular structure of a leaf.

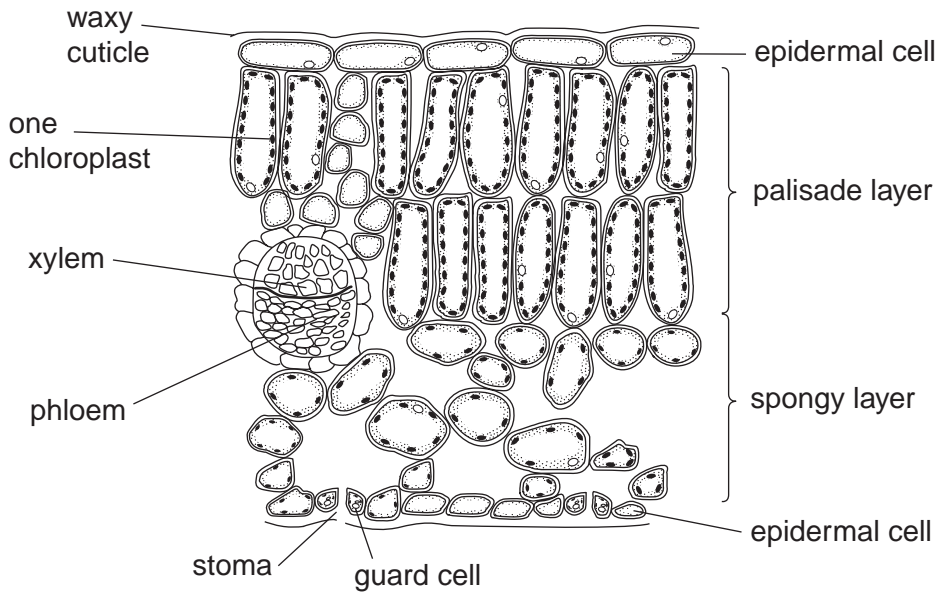

(a) (i) Describe the **job** of xylem.

.....
[1]

(ii) Describe the **structure** of xylem.

.....
[1]

(b) The leaf is adapted for efficient photosynthesis.

(i) Photosynthesis needs efficient gas exchange.

Explain how the spongy layer is adapted for efficient gas exchange.

.....

[2]

(ii) Describe and explain **one other** way the leaf is adapted for photosynthesis.

.....
[1]

[Total: 5]

Section B – Module C4

4 This question is about the reactions of acids.

(a) Look at the diagram. It shows the apparatus used to neutralise an acid with an alkali.

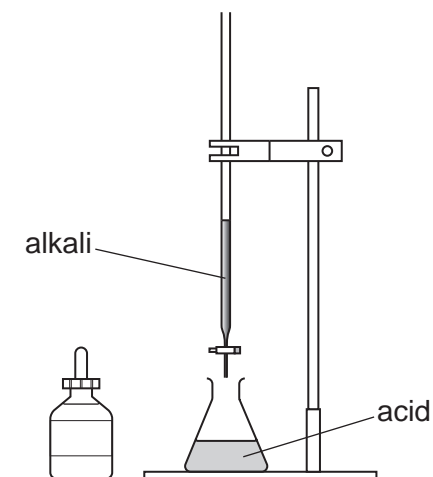

The alkali is added to the acid.

The pH number of the solution increases.

Explain why.

.....[1]

(b) Calcium carbonate reacts with hydrochloric acid.

A salt called calcium chloride is made.

Calcium carbonate also reacts with **nitric acid**.

Write down the **name** of the salt that is made.

.....[1]

(c) Copper oxide, CuO , neutralises hydrochloric acid, HCl .

Copper chloride, CuCl_2 , and water are made.

(i) What type of substance is copper oxide?

Choose from the list.

allotrope

base

fertiliser

salt

answer [1]

(ii) Write a balanced **symbol** equation for this reaction.

..... [2]

[Total: 5]

5 Julie works for a drugs company.

She is making a new medicine to treat heart disease.

(a) One of the chemicals needed to make the medicine is extracted from a plant.

Describe **one** way chemicals can be extracted from plants.

Your answer should include

- what is done to the plant
- how the chemical is removed
- how the chemical is purified.

You may wish to draw a diagram.

.....

.....

.....

.....

.....

.....[3]

(b) A new medicine is expensive to develop.

Research and development costs contribute to the high costs of medicines.

Explain how.

.....

.....[1]

[Total: 4]

6 This question is about chemical calculations.

(a) Calcium hydroxide has the formula Ca(OH)_2 .

Calculate the relative formula mass (M_r) of calcium hydroxide.

(The relative atomic mass (A_r) for Ca = 40, for O = 16 and for H = 1.)

.....

answer [1]

(b) Calcium carbonate reacts with hydrochloric acid.

Calcium chloride, carbon dioxide and water are made.

Look at the symbol equation for the reaction.



Calculate the mass of calcium chloride, CaCl_2 , that can be made from 50g of calcium carbonate, CaCO_3 .

(The relative atomic mass (A_r) for Ca = 40, for C = 12, for O = 16, for H = 1 and for Cl = 35.5.)

.....

answer [2]

[Total: 3]

7 This question is about drinking water.

(a) Water purification has three processes.

They are **filtration**, **sedimentation** and **chlorination**.

Complete the table to explain why each process is used.

Sedimentation has been done for you.

process	why it is used
filtration
sedimentation	It allows very small solid particles to settle out.
chlorination

[2]

(b) Drinking water can be made by the distillation of sea water.

Look at the diagram. It shows the distillation of sea water.

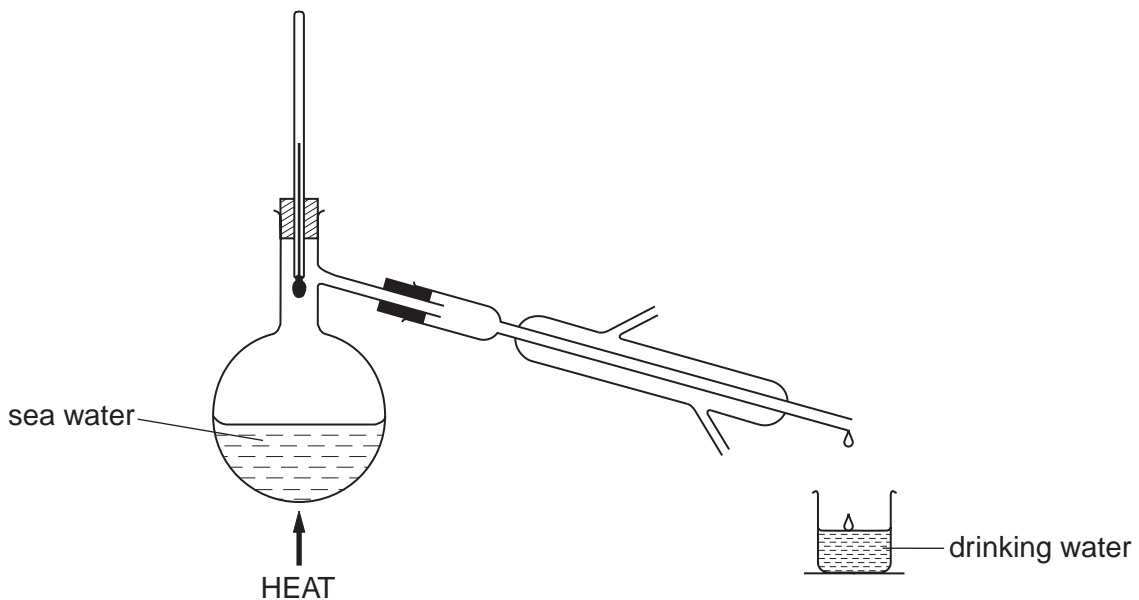

The distillation of sea water to make drinking water is an expensive process.

Explain why.

.....[1]

(c) Drinking water sometimes contains chloride ions.

Silver nitrate reacts with sodium chloride.

Sodium nitrate and silver chloride are made.

Write a **word** equation for this reaction.

.....[1]

[Total: 4]

8 Look at the diagrams. They show the structures of diamond and graphite.

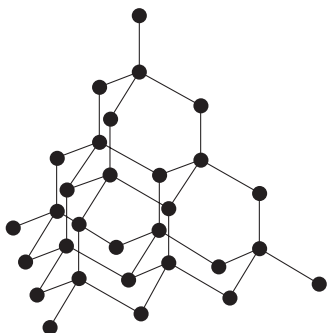

diamond

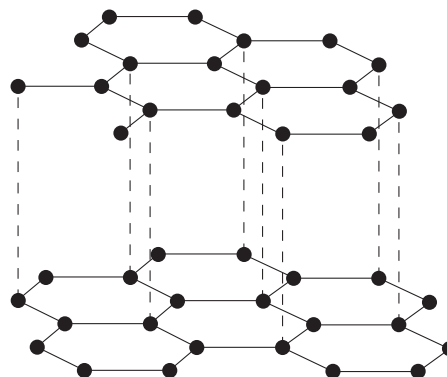

graphite

(a) Diamond is used in cutting tools because it is hard and has a high melting point.

Diamond is also used to make jewellery.

Explain why.

.....[1]

(b) Diamond does not conduct electricity.

Explain why.

.....[1]

(c) Look at the diagram.

It shows the apparatus used in the electrolysis of a solution.

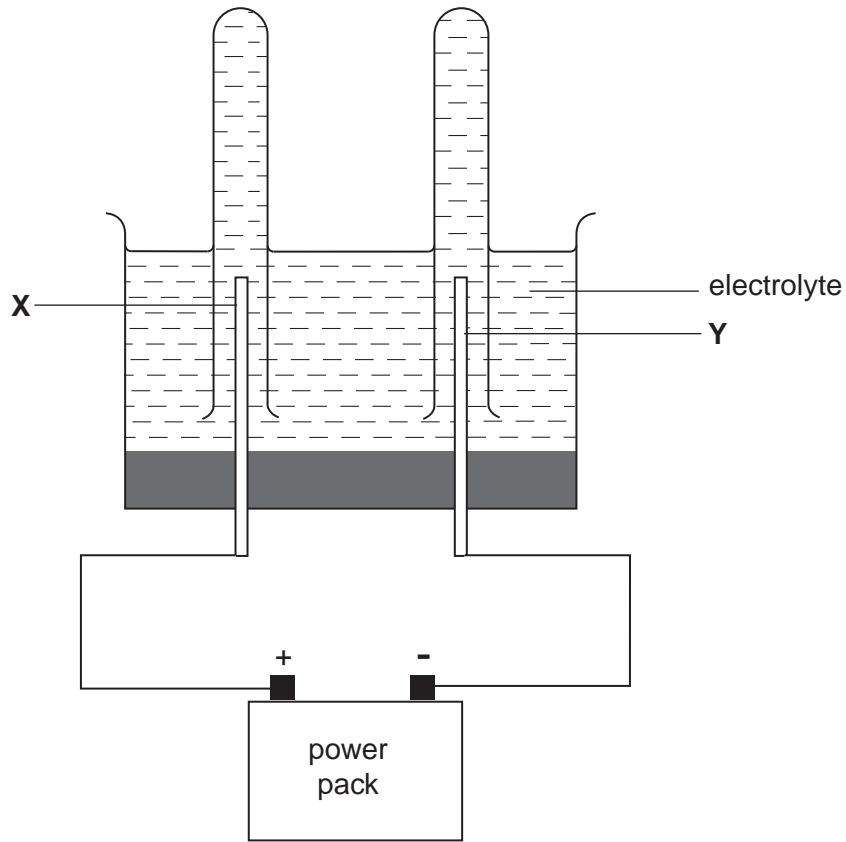

Electrodes **X** and **Y** are both made of graphite.

Suggest why.

.....[1]

(d) Buckminsterfullerene is another solid form of carbon.

It is used to make **nanotubes**.

Nanotubes can be used as semiconductors in electrical circuits.

Write down **one other** use of nanotubes.

Choose from the list.

- industrial catalysts**
- lubricants**
- making fertilisers**
- pencil leads**

answer

[1]

[Total: 4]

[Turn over

Section C – Module P4

9 (a) Static electricity can be dangerous in lightning strikes.

(i) Write down **one other** situation where static electricity can be dangerous.

.....
.....[1]

(ii) How can this danger be reduced?

.....
.....[1]

(b) Look at the pictures.

Petra holds two strips of polythene in her hand.

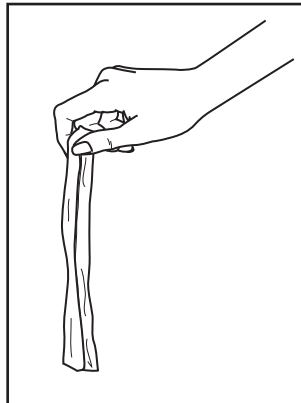

When she rubs the strips with a duster, the two strips move apart.

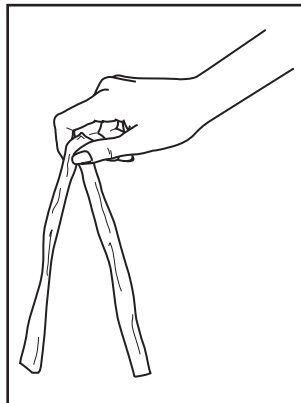

Explain why the two strips move apart.

In your answer, write about

- charges
- forces.

.....

.....

.....

.....

.....

.....[3]

(c) Static electricity can be useful in spray painting cars.

During the process, the paint particles and the car are charged.

(i) All the paint particles are given the **same** charge.

Explain why.

.....
.....[1]

(ii) The car is given an **opposite** charge to the paint particles.

Explain why.

.....
.....[1]

(d) Write down **one advantage** of painting cars using static electricity.

.....
.....[1]

[Total: 8]

10 Chris builds this circuit.

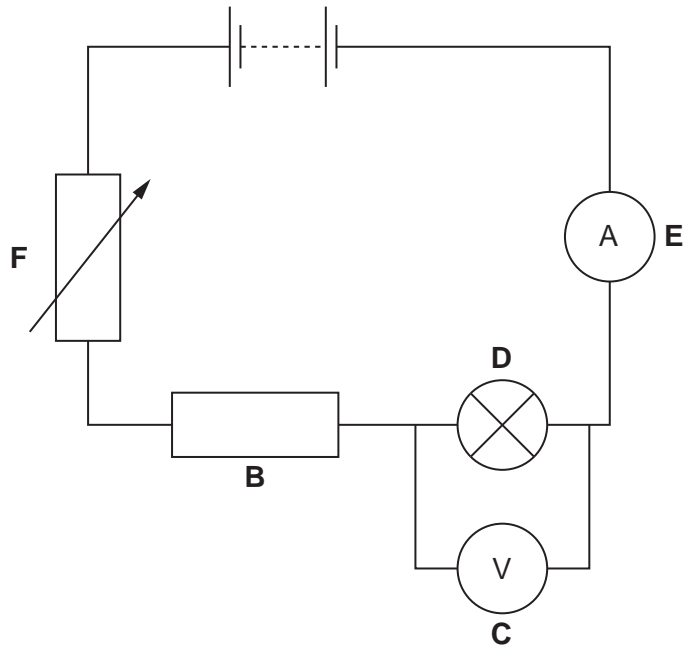

(a) She changes the **current** flowing in the circuit.

Which component does she use to change the current in the circuit?

Choose from **B, C, D, E** or **F**.

answer

[1]

(b) Chris takes the readings on the two meters.

The reading on the ammeter is 0.5 A.

The reading on the voltmeter is 3 V.

Calculate the resistance of the lamp.

The equations on page 2 may help you.

.....

answer ohms

[2]

[Total: 3]

11 (a) Radioactive sources can be used as **tracers** in medicine.

They give out beta or gamma radiation.

(i) Why are alpha sources **not** used as tracers?

.....
.....[1]

(ii) How does the radioactive tracer get into the body?

.....
.....[1]

(iii) How is information from the tracer collected?

.....
.....[1]

(b) Gamma rays and X-rays have similar properties and similar wavelengths.

They are made in different ways.

How are X-rays made?

.....
.....
.....
.....[2]

[Total: 5]

12 This question is about the breakdown of nuclei.

(a) Selina measures the activity from some radioactive material.

It gives 1600 counts per minute.

The half-life of the radioactive material is 30 minutes.

Calculate the count rate after 2 hours.

.....
.....
.....

answer counts per minute [2]

(b) The reaction that produces heat in a nuclear reactor is a **chain reaction**.

If left alone, it can go out of control.

Explain how scientists stop a nuclear reaction going out of control.

.....
.....
.....
.....[2]

[Total: 4]

END OF QUESTION PAPER

Permission to reproduce items where third-party owned material protected by copyright is included has been sought and cleared where possible. Every reasonable effort has been made by the publisher (OCR) to trace copyright holders, but if any items requiring clearance have unwittingly been included, the publisher will be pleased to make amends at the earliest possible opportunity.

OCR is part of the Cambridge Assessment Group. Cambridge Assessment is the brand name of University of Cambridge Local Examinations Syndicate (UCLES), which is itself a department of the University of Cambridge.

The Periodic Table of the Elements

1	2	3	4	5	6	7	0										
7 Li lithium 3	9 Be beryllium 4	11 Na sodium 11	12 C carbon 6	13 Al aluminium 13	14 N nitrogen 7	15 P phosphorus 15	16 S sulfur 16	17 Cl chlorine 17	18 Ar argon 18								
19 K potassium 19	20 Ca calcium 20	21 Sc scandium 21	22 Ti titanium 22	23 V vanadium 23	24 Cr chromium 24	25 Mn manganese 25	26 Fe iron 26	27 Co cobalt 27	28 Ni nickel 28	29 Cu copper 29	30 Zn zinc 30	31 Ga gallium 31	32 Ge germanium 32	33 As arsenic 33	34 Se selenium 34	35 Br bromine 35	36 Kr krypton 36
37 Rb rubidium 37	38 Sr strontium 38	39 Y yttrium 39	40 Zr zirconium 40	41 Nb niobium 41	42 Mo molybdenum 42	43 Tc technetium 43	44 Ru ruthenium 44	45 Rh rhodium 45	46 Pd palladium 46	47 Ag silver 47	48 Cd cadmium 48	49 In indium 49	50 Sn tin 50	51 Sb antimony 51	52 Te tellurium 52	53 I iodine 53	54 Xe xenon 54
55 Cs caesium 55	56 Ba barium 56	57 La* lanthanum 57	72 Hf hafnium 72	73 Ta tantalum 73	74 W tungsten 74	75 Re rhenium 75	76 Os osmium 76	77 Ir iridium 77	78 Pt platinum 78	79 Au gold 79	80 Hg mercury 80	81 Tl thallium 81	82 Pb lead 82	83 Bi bismuth 83	84 Po polonium 84	85 At astatine 85	86 Rn radon 86
[223] Fr francium 87	[226] Ra radium 88	[227] Ac* actinium 89	[261] Rf rutherfordium 104	[262] Db dubnium 105	[266] Sg seaborgium 106	[264] Bh bohrium 107	[277] Hs hassium 108	[268] Mt meitnerium 109	[271] Ds darmstadtium 110	[272] Rg roentgenium 111	Elements with atomic numbers 112-116 have been reported but not fully authenticated						

1	H hydrogen 1
---	--------------------

relative atomic mass
atomic symbol
name
atomic (proton) number

* The lanthanoids (atomic numbers 58-71) and the actinoids (atomic numbers 90-103) have been omitted.

The relative atomic masses of copper and chlorine have not been rounded to the nearest whole number.